

standard plus[®]

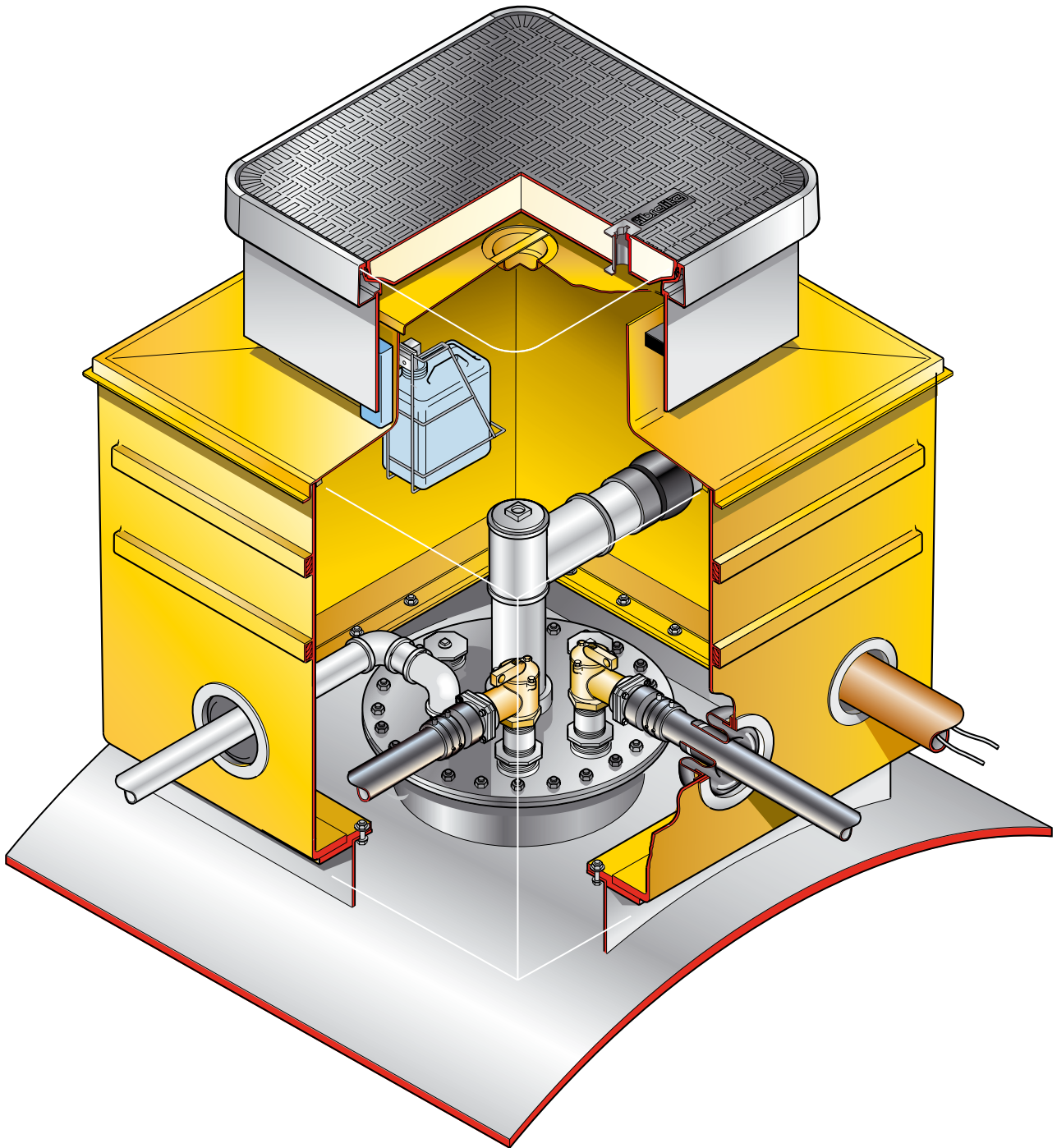

System shown with S/CS/Sealkit



FIBRELITE

Category: **HEIGHT ADJUSTABLE SQUARE CHAMBER SYSTEMS**

Product Description: 1.2m square bolted base chamber with a corbel, internal lid, adjustable skirt and square 760mm flat sealed cover. (1m square tank flange connection).

Page No: **1**

Product Code: **S6-376**

Date: **July 2011**

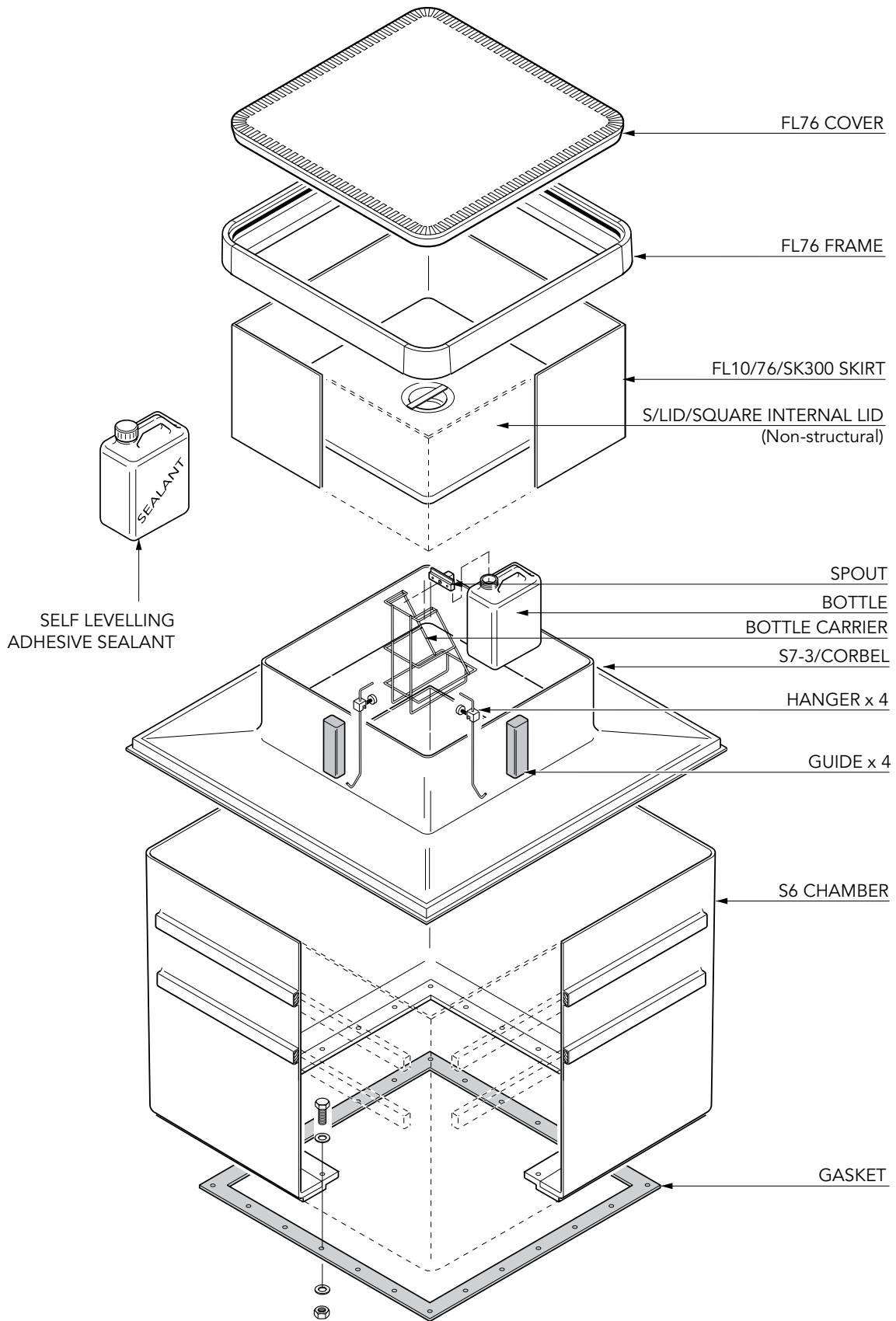

Category: **HEIGHT ADJUSTABLE SQUARE CHAMBER SYSTEMS**

Product Description: 1.2m square bolted base chamber with a corbel, internal lid, adjustable skirt and square 760mm flat sealed cover. (1m square tank flange connection).

Page No: **2**

Product Code: **S6-376**

Date: **July 2011**

! VERY IMPORTANT !
 OUTER EDGE "A" OF FRAME SET 5 - 10MM
 ABOVE GENERAL FORECOURT AREA WITH
 CONCRETE RAMPED AWAY OVER 300MM.

TYPICAL INSTALLATION

CONCRETE

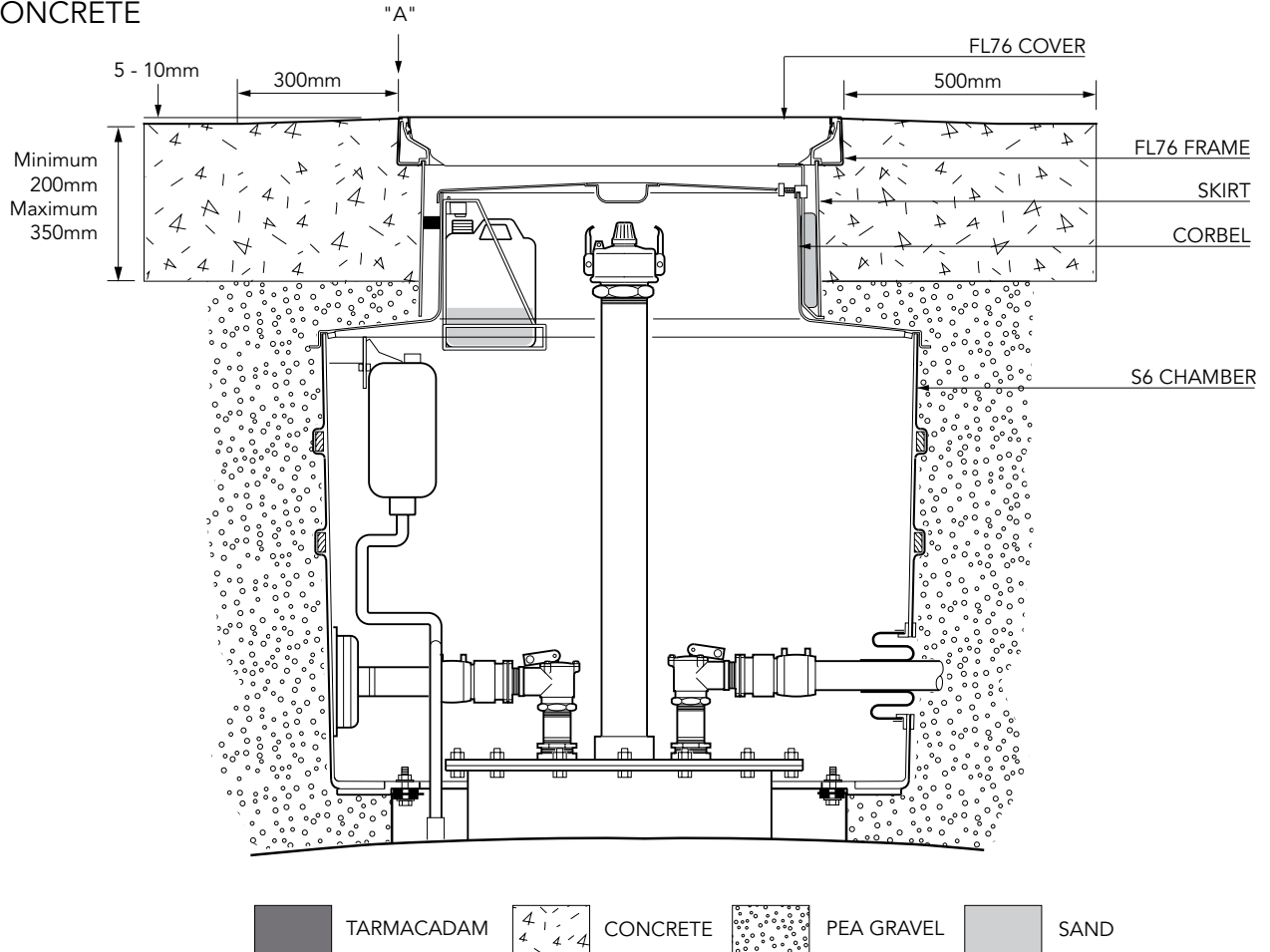

ALTERNATIVE INSTALLATION ADVICE

TARMACADAM

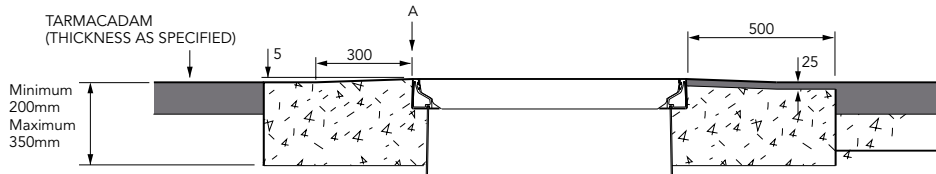

SETTS

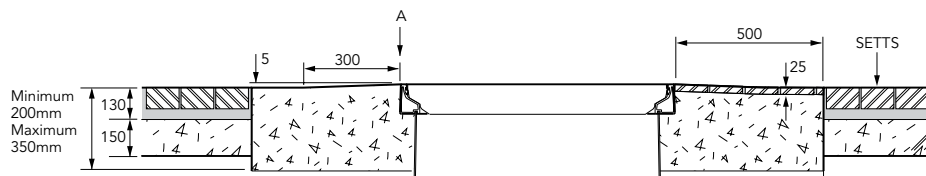

Category: **HEIGHT ADJUSTABLE SQUARE CHAMBER SYSTEMS**

Product Description: 1.2m square bolted base chamber with a corbel, internal lid, adjustable skirt and square 760mm flat sealed cover. (1m square tank flange connection).

Page No: **3**

Product Code: **S6-376**

Date: **July 2011**

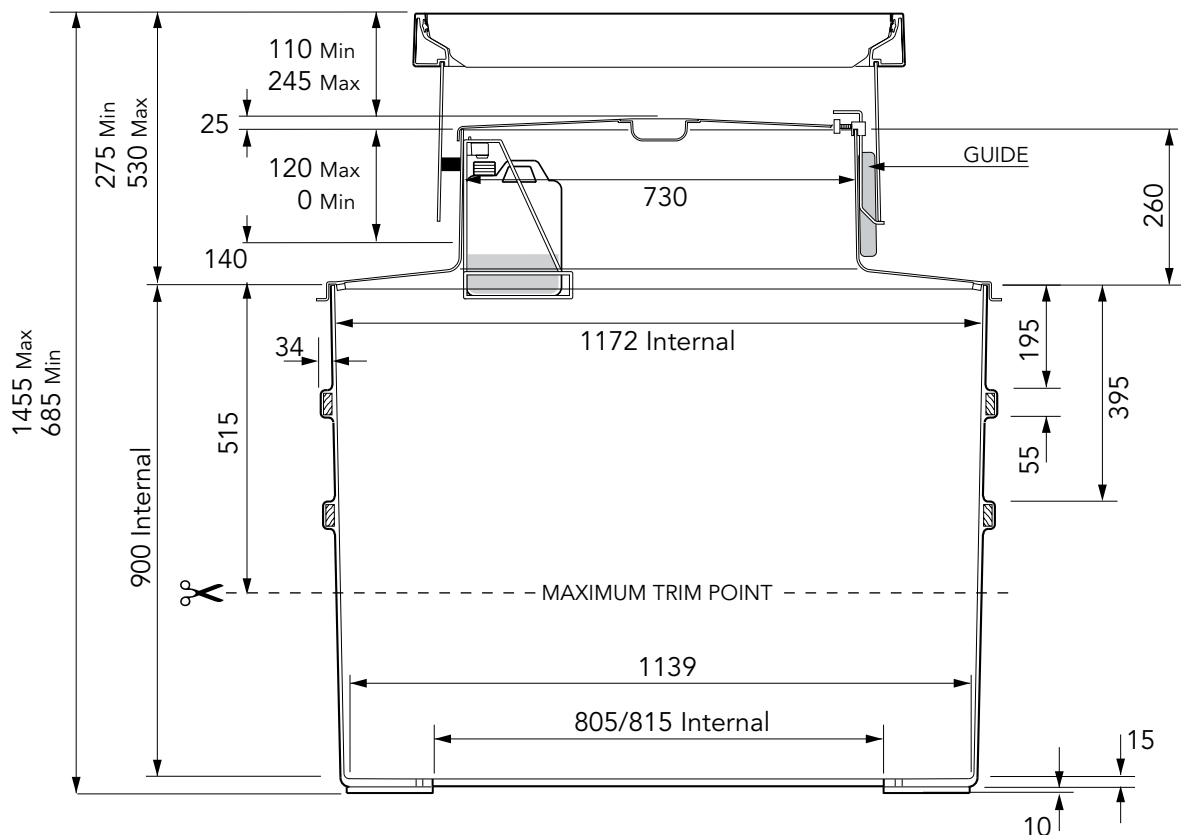
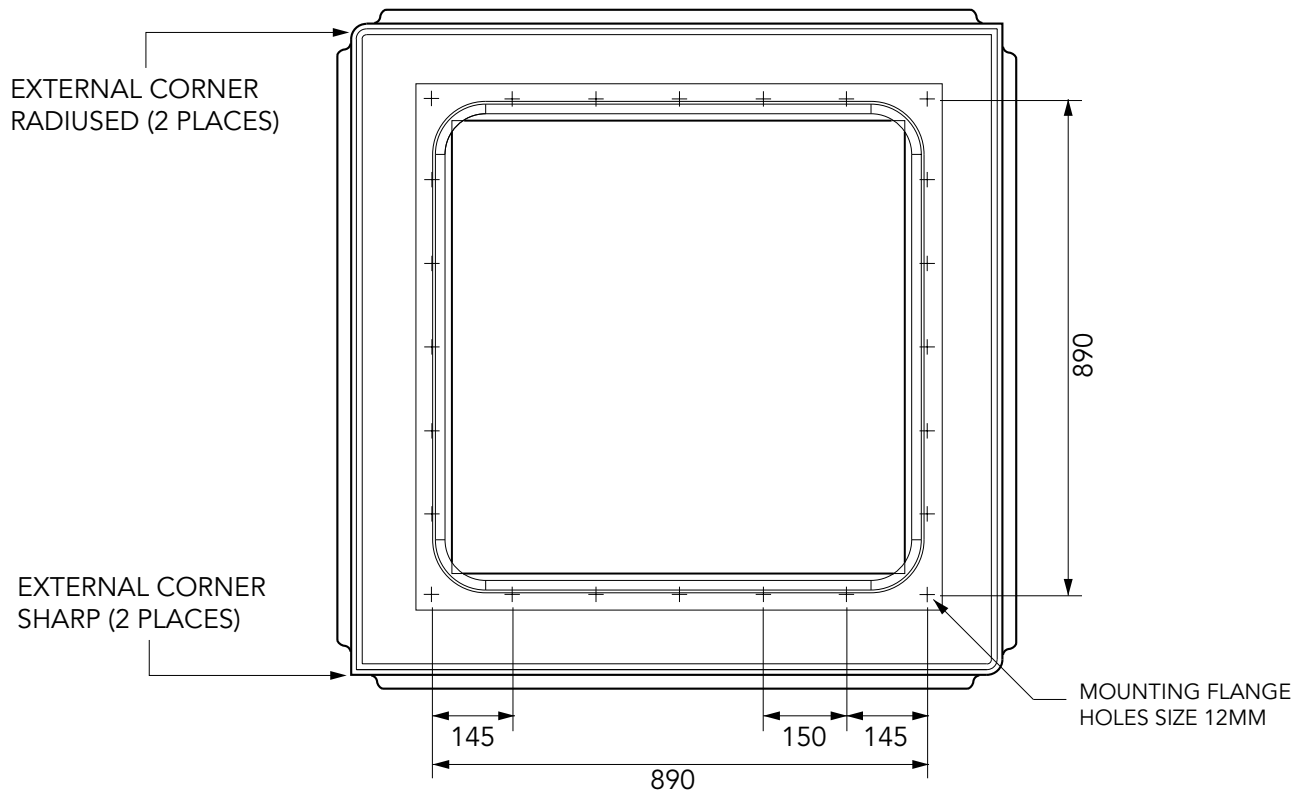

Sealed system dimensions



Category:	HEIGHT ADJUSTABLE SQUARE CHAMBER SYSTEMS		
Product Description:	1.2m square bolted base chamber with a corbel, internal lid, adjustable skirt and square 760mm flat sealed cover. (1m square tank flange connection).		
Page No:	4	Product Code:	S6-376
		Date:	July 2011

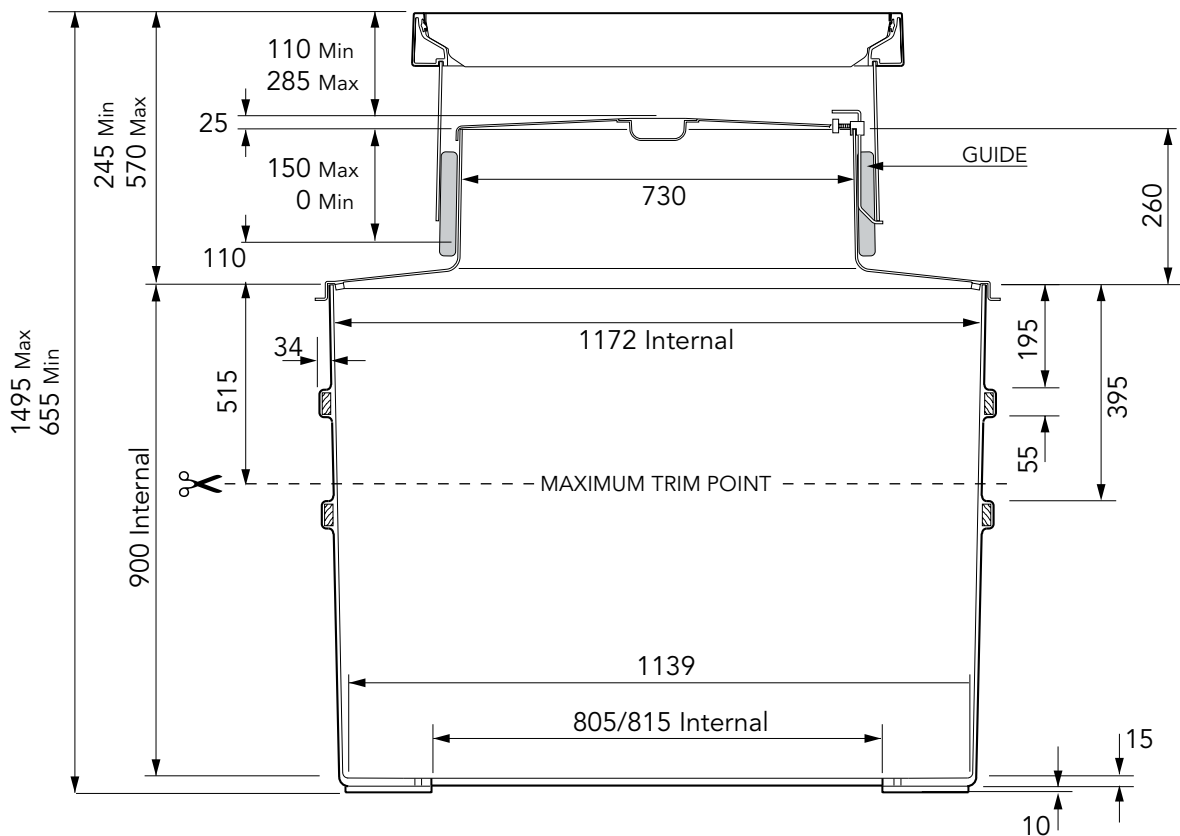
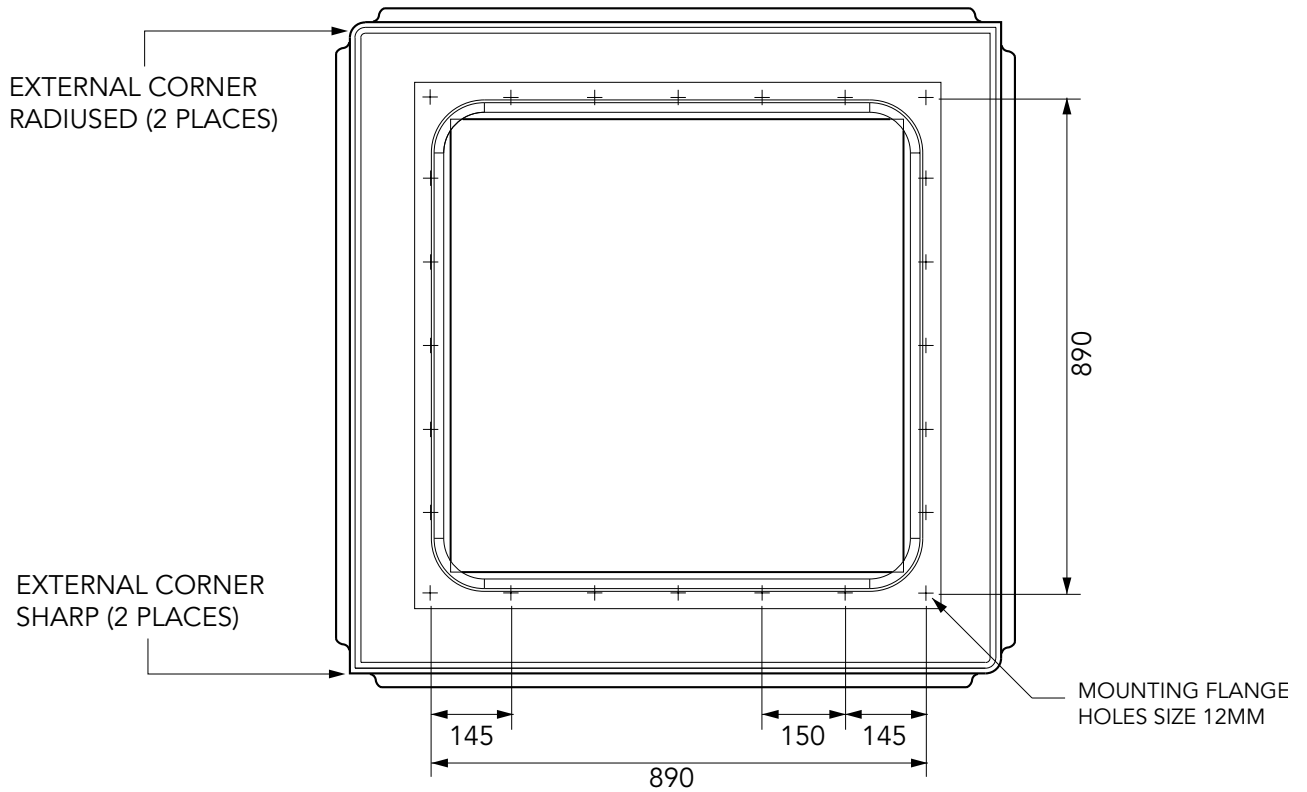

Unsealed system dimensions



Category: **HEIGHT ADJUSTABLE SQUARE CHAMBER SYSTEMS**

Product Description: 1.2m square bolted base chamber with a corbel, internal lid, adjustable skirt and square 760mm flat sealed cover. (1m square tank flange connection).

Page No: **5**

Product Code: **S6-376**

Date: **July 2011**