

<b>Notes:</b>  BS EN 124 1994 PAS 26 1998	 MODEL FL76 CLASS C250	Category: <b>ACCESS COVER &amp; FRAME - SEALED</b>	
		Product Description: <b>FL76 - 760mm x 760mm flat sealed composite cover with an aluminium frame.</b>	
For reference purposes only. This drawing is not a specification.	Drawing No: <b>13760</b>		Product Code: <b>FL76</b>
	Date: <b>Mar 2000</b>		Revisions: <b>0</b>

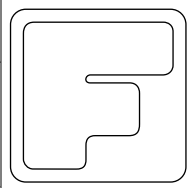

**FIBRELITE**

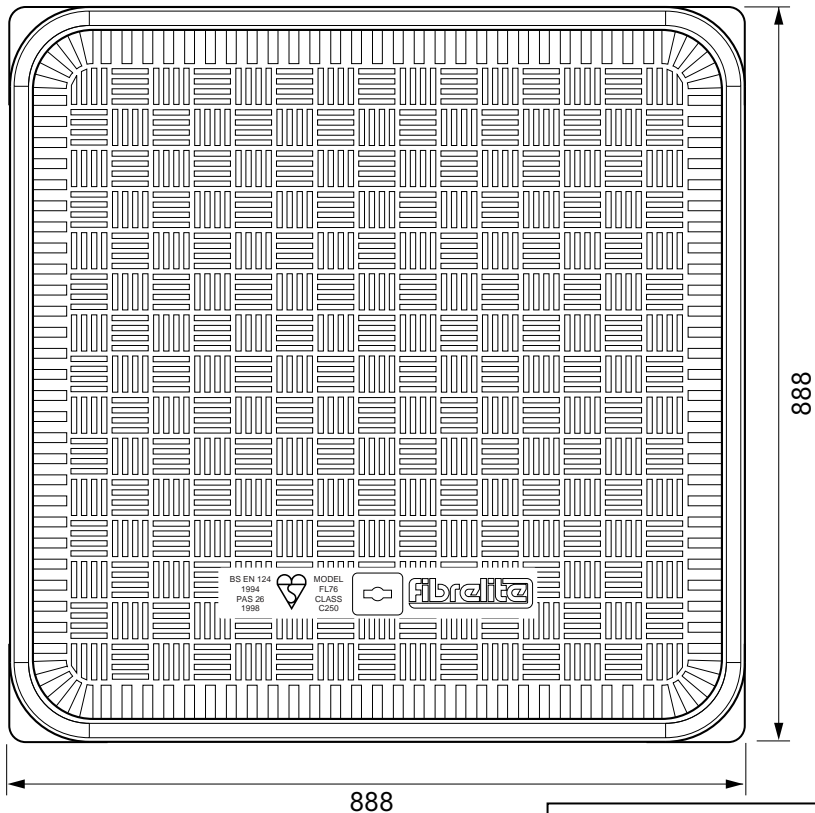
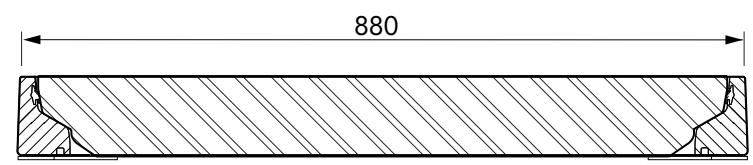
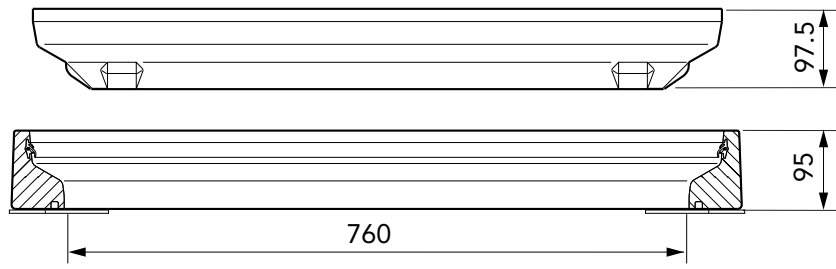

**COVER TYPES**

Code	Description	Cover Weight	Frame Weight
FL76 C250 *	FL76 Tank Cover, Class C250	29Kg	12Kg
FL76 D400	FL76 Tank Cover, Class D400	41Kg	12Kg
FL76-1000	FL76 Airport Cover	41Kg	13.3Kg
FL76 C250 TCR	FL76 Tank Cover, TCR	29Kg	12Kg
FL76 D400 TCR	FL76 Tank Cover, TCR, Class D400	40Kg	12Kg

\* Awarded British Standard Kite Mark  
**TCR:** Temperature & chemical resistant cover.

**Notes:**

BS EN 124  
 1994  
 PAS 26  
 1998



MODEL  
 FL76  
 CLASS  
 C250

For reference purposes only.  
 This drawing is not a specification.

Category: **ACCESS COVER & FRAME - SEALED**

Product Description: **FL76 - 760mm x 760mm flat sealed composite cover with an aluminium frame.**

Drawing No: **13761**

Date: **Mar 2000**

Product Code: **FL76**

Revisions: **0**

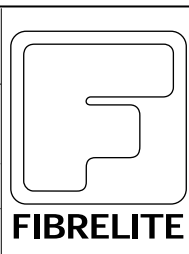

## CONCRETE

### VERY IMPORTANT

OUTER EDGE "A" OF FRAME SET 5MM ABOVE GENERAL FORECOURT AREA WITH CONCRETE RAMPED AWAY OVER 300MM

### VERY IMPORTANT

The underside of the frame must be adequately supported by concrete.

Expansion joint filled with petrol resistant mastic.

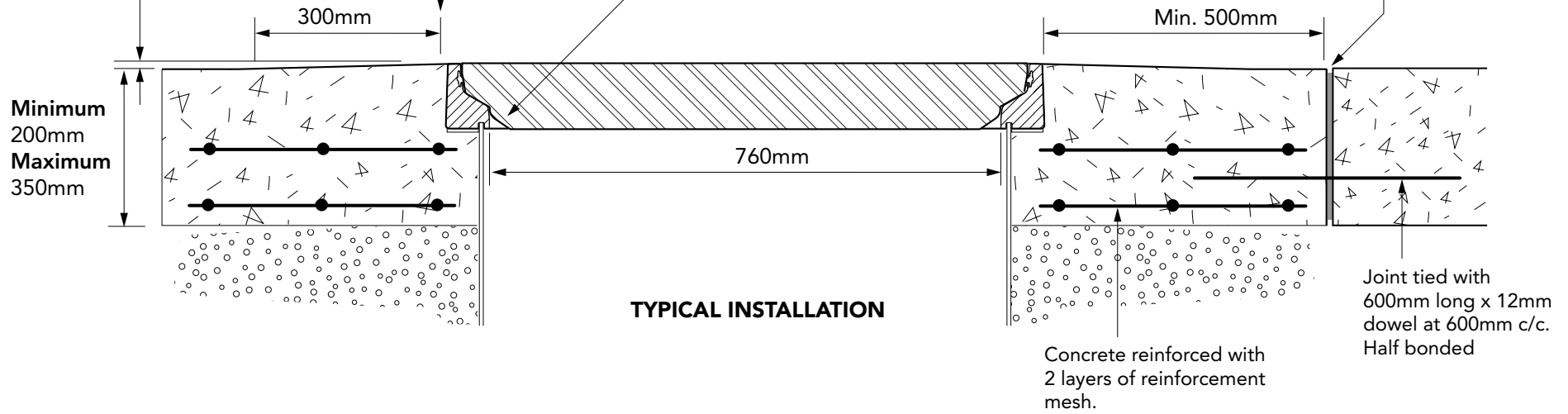

## TARMACADAM

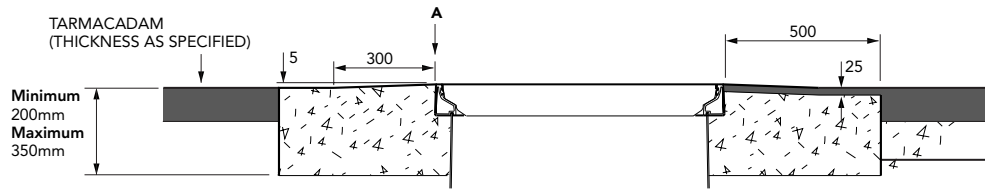

## SETTS

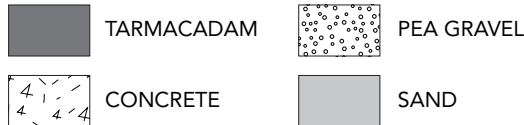
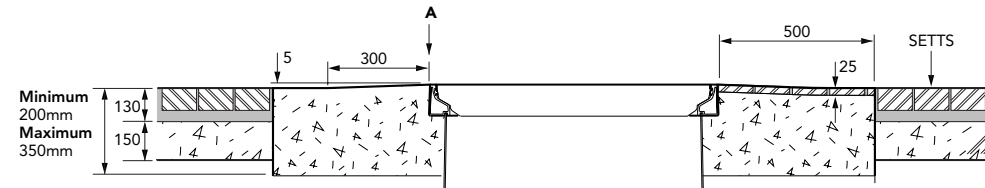

### Notes:

BS EN 124  
1994  
PAS 26  
1998

MODEL  
FL76  
CLASS  
C250

For reference purposes only.  
This drawing is not a specification.

Category: **ACCESS COVER & FRAME - SEALED**

Product Description: **FL76 - 760mm x 760mm flat sealed composite cover with an aluminium frame.**

Drawing No: **13762**

Date: **Mar 2000**

Product Code **FL76**

Revisions: **0**

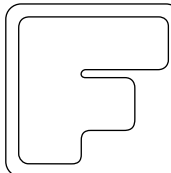

**FIBRELITE**