

INSTALLATION AND SERVICE INSTRUCTIONS FOR 1012, 1014, 1015 AND 1017 SERIES PUMPS

GENERAL DESCRIPTION

Pumping Principles Page 2

INSTALLATION

Location Page 3
Proper Installation Page 3
Filter Protection Page 4
Start Up Page 5

SERVICE

Disassembly Of Seal Page 6
Disassembly Of Pump Page 7
Inspection Page 7
Re-assembly Of Pump Page 8

PUMP SELECTION

Flow Rates Page 9
Diagram Page 9
Parts List Page 9

FIELD CHECKLIST

What To Look For Page 10
Materials Return Page 11



**TUTHILL
CORPORATION**

**Tuthill Pump
Division**

12500 South Pulaski Road
Alsip, Illinois USA 60803
Tel 708 389-2500 Fax 708 388-0869
E-mail: tutpump@tuthill.com

General Description

Both types can be supplied with automatic reversing (Style "R"), feature steam jackets (through which steam or other heating medium may be forced to melt or reduce viscosity of materials to permit rotation of the pump at starting. Conversely, when desirable, cooling water may be forced through these jackets). These pumps can also be supplied with an integral relief valve. Nitrile, Neoprene and Viton seals are available with these units along with P.T.F.E. or Mellinex gaskets. When pumping temperatures in excess of 100⁰c are used, special H.T. gaskets are also available.

The Pumping Principle

Tuthill internal-gear principle is based upon the use of a rotor, idler gear and crescent shaped partition that is cast integrally with the cover. (See accompanying figure). Thus, only two moving parts comprise this efficient pumping element. Power is applied to the rotor and transmitted to the idler gear with which it meshes. The space between the outside diameter of the idler and the inside diameter of the rotor is sealed by the crescent. When the pump is started, there is an increase in volume as the teeth come out of mesh. This creates a partial vacuum, drawing the liquid into the pump through the suction port. The liquid fills the space between the teeth of the idler and rotor and is carried past the crescent partition to the pressure side of the pump. When the teeth mesh on the pressure side, the liquid is forced from the spaces and out through the discharge port.

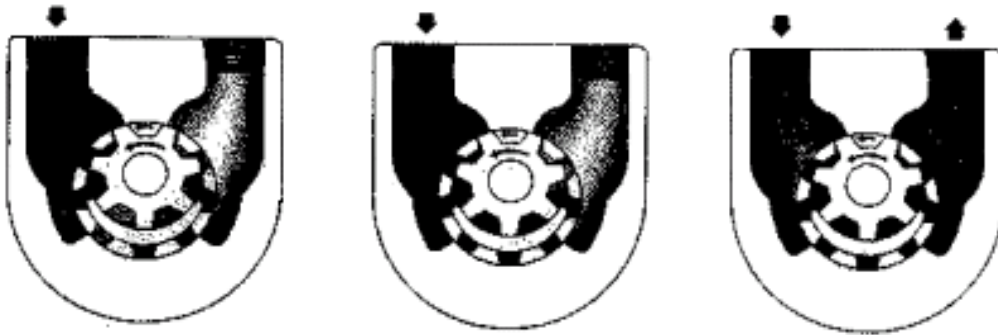

WARNING

Failure to follow these instructions could result in serious bodily injury or death.

These pumps should **not** be used for handling plain water, corrosive or abrasive liquids or liquids not possessing adequate lubricity.

Do not attempt to work on any Tuthill pump installation before completing the steps below.

Disconnect the drive so that it cannot be started while work is being performed.

Review the Material Safety Data Sheet (MSDS) applicable to the liquid being pumped to determine its characteristics and the precautions necessary to ensure safe handling.

Vent all pressure within the pump through the suction or discharge lines.

All Tuthill pumps contain residual ISO 32 lube oil from the factory production test. Determine if this is compatible with the fluid you are pumping. If the fluid is incompatible, consult the factory.

Location

The pump should be located as close to the source of supply as conditions will permit, below the level of the liquid in the reservoir, if possible. Pumps should be located in a dry and clean place, with space to work around them.

When necessary to locate pumps in pits, provisions should be made to safeguard against floods. Care must be taken to properly support the suction and discharge piping so that no strain can be put on the pump from either its weight or expansion. Piping strains are very often the cause of misalignment, hot bearing, worn couplings and vibrations.

Proper Installation

A large percentage of unsatisfactory pump installations is caused by failure to observe the natural laws limiting the suction lifts on volatile materials. At temperatures of approximately 70°F or lower, kerosene and light fuel oils may be pumped at nearly full volumetric efficiency when combined vertical lift and friction in the suction line do not cause a vacuum to exceed 10 inches of mercury at the suction port of the pump. Ten inches vacuum on kerosene oil is equal to approximately fourteen feet of vertical lift without pipe friction. This varies with the temperature and various oils, but if, in laying out the suction line, the maximum vacuum is kept at this figure or lower, good results may be expected. If this vacuum is exceeded, it is almost certain to result in cavitation, loss of volume and a noisy installation.

When pipelines are installed, an inverted "U" bend should be incorporated in the suction line close to the pump to trap liquid in the pump for priming. The suction line must be kept free from air leaks and air pockets.

When handling liquids of high viscosity, such as asphalt, heavy gear lubricants, linseed oil, Bunker "C" fuel oil, molasses, etc., the speed of the pumps and the running clearances are important. Consult Tuthill UK, whenever unusual conditions of speed, pressure, vacuum or viscosity are encountered.

Before initial start of the pump, it is recommended that some of the liquid to be pumped be introduced into the pump ports to insure wetting of the rotation elements. Check alignment and rotation of the driver to see that pump will rotate in the designated proper direction of rotation.

Filter Protection

Piping or tubing should be cleaned out thoroughly to remove chips and pipe scale before connecting the piping to the pump.

Neglect of this precaution may result in damage to the pump when it is put in operation. The suction piping should be as short and direct as possible. Grit, pipe chips, or other foreign substance that is allowed to pass through the pump, will almost surely injure and possibly ruin it. Always remember the following in the selection and position of a filter:

1. A filter should be installed to protect the pump whenever conditions permit.
2. When uncertain of pressure drop through the filter, obtain this data from manufacturer, giving pump capacity and type of liquid to be handled.
3. Install filter according to arrows or notation designating flow.
4. Have filter accessible for servicing.
5. Use duplex type where shutdown during servicing is not permitted.
6. Provide a vacuum gauge in the suction line for determining when the filter requires cleaning
7. The greater the free opening, the less attention the filter will require.

 **WARNING**

All Tuthill pumps contain residual ISO 32 lube oil from the factory production test. Determine if this is compatible with the fluid you are pumping. If the fluid is incompatible, consult the factory.

If the pump is to operate at elevated temperatures, it should be brought up to operating temperature gradually. Rapid or sudden introduction of liquid at an elevated temperature into the cold liquid chamber of the pump could cause damage to the seal or other internal parts.

Do not run the pump dry. This could cause severe damage to the seal, bushings and/or metal parts. Temperatures must not exceed 200°C without prior consent

Startup

Prior to starting the pump double check the following:

- Pressure and vacuum gauges should be installed as close as possible to the pump.
- Rotate pump shaft to ensure it turns freely without binding.
- Recheck alignment and ensure all guards are in place.
- Make sure piping is independently supported and no strain is being transmitted to the pump.
- Make sure the safety relief valve is installed correctly.
- Check pump rotation.
- Open suction and discharge gate valves.
- Check for any leaks once gate valves are open.

After completing these checks the pump can be started.

 **CAUTION**

The pump should not be run dry. If after approximately 60 seconds there is no discharge of liquid, stop the pump and investigate the possible cause. Failure to comply with this could cause severe damage to internal seals, bushings and/or metal parts.

WARNING

Failure to follow these instructions could result in serious bodily injury or death.

Do not attempt to work on any Tuthill pump installation before completing the steps below.

Disconnect the drive so that it cannot be started while work is being performed.

Review the Material Safety Data Sheet (MSDS) applicable to the liquid being pumped to determine its characteristics and the precautions necessary to ensure safe handling.

Vent all pressure within the pump through the suction or discharge lines.

All Tuthill pumps contain residual ISO 32 lube oil from the factory production test. Determine if this is compatible with the fluid you are pumping. If the fluid is incompatible, consult the factory.

Disassembly of Seal

1. Deburr shaft especially around the keyway area.
2. Hold the pump in a vice, cover down and remove the grub screw from the lockable shaft bearing collar. Remove collar.
3. Unscrew the 3 off 6mm bolts to remove the bearing housing, (this may be tight due to the sealant used during assembly). This can be done by holding the bearing housing and twisting the body.
4. Remove static seal plate from bearing housing, noting dowel pin in plate location face, and place to one side.
5. Undo the three grubscrews on the mechanical seal collar and gently pull off shaft, again put to one side. (Remove secondary collar if there is one present.) Press out the seal housing bearing.
6. Inspect rotor, if badly scored in seal or bearing area, rotor should be replaced. Also check seal faces for the same scoring. Remove O-rings and check for deformation, again replace if there is any doubt.
7. Clean all parts thoroughly and replaced static seal plate ensuring that the plate is positioned correctly over the dowel.
8. Refit collar to the shaft, using a 0.002" feeler gauge between the collar and flange (if it originally had one fitted). Lubricate O-ring inside the mechanical seal with a light oil and guide down the shaft. If the pump had a collar then push the mechanical seal down onto the collar and retighten the three grubscrews, if the pump did not have a collar then use a 0.002" feeler gauge between the flange and the mechanical seal to create the correct end float. And retighten the three grub screws.
9. Apply the new bearing housing gasket and refit the bearing housing.
10. Press in the lockable bearing. Take the lockable collar and place over bearing ensuring that it is fully located and while holding the collar rotate the shaft clockwise. Take a 3/16th pin

punch and gently tap the collar counterclockwise until the grub screw lines up with the indentation on the shaft and then retighten.

Disassembly of Pump

1. Deburr shaft especially around the keyway area.
2. Hold the pump in a vice, cover down, and remove the grub screw from the lockable shaft bearing collar. Remove collar.
3. Unscrew the 3 off 6mm bolts to remove the bearing housing (this may be tight due to the sealant used during assembly). This can be done by holding the bearing housing and twisting the body.
4. Remove static seal plate from bearing housing, noting dowel pin in plate location face, and place to one side.
5. Undo the three grubscrews on the mechanical seal collar and gently pull off shaft, again put to one side. (Remove secondary collar if there is one present). Press out the seal housing bearing.
6. Mark the cover and body for orientation and hold in the vice with the shaft pointing downwards. Remove the 8 off 8mm cap head screws and remove the cover assembly by pulling upwards, place to one side.
7. Making sure there is sufficient clearance underneath the pump, (to prevent damage to the rotor vanes) press the rotor out through the body.
8. The individual parts must now be inspected for damage. The keyway in the end of the rotor must be in good condition and there must not be any deep scratches or grooves on the following surfaces:
 - a. The ID surface of the housing
 - b. The OD of the rotor
 - c. The end face of the rotor
 - d. The OD of the idler
 - e. Both faces of the idler
 - f. The inside surfaces of the cover including surfaces on the crescent
 - g. Areas on the shaft of the rotor were the seal seats.

Inspection

Check cover, housing, rotor and idler for wear, chipped or broken teeth. Drop off in capacity is generally caused by the abrasive action of foreign materials in the oil, resulting in end play of the rotor.

Check for side movement in the rotor assembly, as this indicates potential bearing failure.

Reassembly of Pump

1. Clean all parts thoroughly using great care to eliminate dirt.
2. Take the body and press the rotor assembly into it's location ensuring that the bearing is square, check that the rotor turns freely in the body.
3. Hold unit in a vice with the shaft pointing downwards.
4. Again using a new gasket and O-ring fit the cover.
5. Make sure the rotor turns freely.
6. Turn the unit over in the vice so that the rotor is pointing upwards again.
7. Refit collar to the shaft, using a 0.002" feeler gauge between the collar and flange (if it originally had one fitted). Lubricate O-ring inside the mechanical seal with a light oil and guide down the shaft. If the pump had a collar then push the mechanical seal down onto the collar and retighten the three grub screws, if the pump did not have a collar then use a 0.002" feeler gauge between the flange and the mechanical seal to create the correct end float. And retighten the three grub screws.
8. Apply the new bearing gasket and refit the bearing housing.
9. Press in the lockable bearing. Take the lockable collar and place over bearing ensuring that it is fully located and while holding the collar rotate the shaft clockwise. Take a 3/16th pin punch and gently tap the collar counterclockwise until the grub screw lines up with the indentation on the shaft and then retighten.

Pump selection

The above pumps are only suitable for liquids having self-lubricating properties. The table below shows the capacity and suggested driving motor size for different speeds and pressures. These figures are based upon pumping a liquid of about 200 S.S.U. viscosity, and with a 10-inch vacuum. While Tuthill pumps will develop as high as 27 inches of vacuum, it is sound engineering to reduce the vacuum to a minimum. The speed of the pump must be reduced when handling liquids of high viscosity and the size on lines increased to prevent cavitation, loss of capacity and high power requirements.

Caution: Remember that the pipeline friction increases at a rapid rate with increase in viscosity. For a given pump and motor, larger pipelines are necessary to maintain the same pump pressure when changing from a thin liquid to a thick liquid. Viscous liquid pumping installations are notoriously under powered, due to lack of knowledge in computing pipeline friction. Handling of viscous liquids is a special hydraulic engineering problem, which the Engineering Department of Tuthill is well equipped to solve for you.

Consult Tuthill Pumps Ltd. in selecting the proper pump, size of motor and pipeline size for your job, giving them the following information:

1. Capacity required.
2. Maximum and minimum liquid temperature when entering the pump.
3. The viscosity at the minimum temperature.
4. Total length of suction pipe and discharge pipe.
5. Suction lift and height to which the pump must force the liquid.

Pump Speed	1425 RPM						960 RPM						720 RPM					
	10		50		100		10		50		100		10		50		100	
Operating Pressure (PSI)	GPM	HP	GPM	HP	GPM	HP	GPM	HP	GPM	HP	GPM	HP	GPM	HP	GPM	HP	GPM	HP
1014	6	0.5	5.3	0.75	4.6	1	4.3	0.33	4	0.5	3.7	0.75	3.3	0.25	3	0.33	2.7	0.5
1015	12	1	11.2	1.5	10.5	2	8	0.5	7.7	1	7.3	1.5	6	0.33	5.7	0.75	5.3	1
1018	24.4	1.5	23.7	2	23	3	16	1	16.7	1.5	15.3	3	12	0.75	11.7	1.5	11.3	2
1020	40.9	2	40.2	4	39.6	7.5	26.7	1.25	26	3	26.3	6	20	1	19.3	2	18.7	3
1022	55.4	3	54.7	5.5	54	10	37.3	2	36.7	4	36	7.5	28	1.5	26.7	3	25.3	4

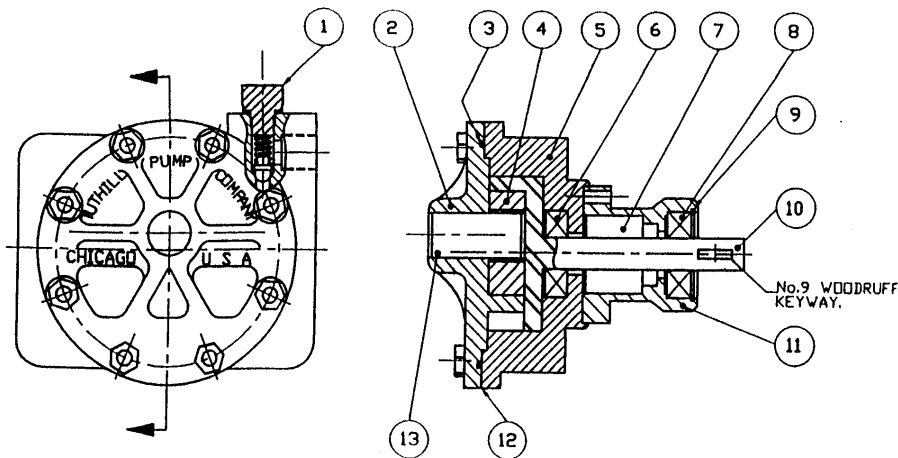

ITEM	DESCRIPTION	QTY	DRAWING No	PART No	MATERIAL
1	Relief Valve	1	A1112UK	LXUK9219	Various
2	Cover	1	A1066UK	3M35-XUK9014	Cast Iron
3	O' Ring	1		BS046	Neoprene
4	Idler Gear	1	11002-A	3M5-1	Steel/Carbon
5	Body	1	1015-015		Cast Iron
6	Bearing	1		2RLS6/2RS	
7	Mechanical Seal	1		680-111-23AX12	
8	Bearing	1		2RLS6/2RS	
9	Circlip	1		NAM300-187	
10	Rotor	1	A21445UK		Steel
11	Seal Housing	1	1015-012		Cast Iron
12	Shims	2			0.006" Melonex
13	Idler Pin	1	5225-A	3M31	Steel

Field checklist

WHAT TO LOOK FOR WHEN:

1. No Oil is delivered.

- a) Suction lift too high for vapour pressures of liquid pumped. While Tuthill Pumps will develop as high as 27 inches of vacuum, it is wise to reduce the vacuum to a minimum.
- b) Bad leaks in suction line or port passages can be detected by submerging pressure line from discharge side of pump into a pail of oil where the air will be seen in the form of bubbles.
- c) Wrong direction of shaft rotation.
(In "R" models, check position of cover boss.)
- d) Pump shaft not rotating. (Check coupling or drive).
- e) Relief valve setting too low. (Discharging fluid through by-pass port.)

2. Capacity is too Low

- a) Suction lift too high.
- b) Air leaks in suction line.
- c) Suction line too small.
(Can be detected by installing a vacuum gauge directly at the pump suction. The maximum vacuum at the pump suction should never exceed 1 5 inches of mercury. It is necessary to keep below 1 5 inches not because of the inability of the pump to handle a higher vacuum, but primarily because of the vaporization that is liable to take place at a higher vacuum. Vaporization caused by higher vacuums will generally result in capacity drop-off.)
- d) Pump speed too slow.
- e) Filter too small or obstructed.
- f) Suction pipe or port not immersed in the liquid deep enough.
- g) Piping improperly installed, permitting air pocket to form in pump.
- h) Increased clearance or wear in the pump will sometimes cause the pump to deliver an insufficient supply of liquid.

A folded gasket or a slight amount of dirt not only will frequently exaggerate the original trouble but will also be the cause of leakage.

3. Pump Works Spasmodically

- a) Leaky suction lines.
- b) Suction lift too high.
- c) Air or vapour in liquid.
- d) Coupling slipping on pump shaft.

4. Pump Wastes Power

- a) Pressure too high.
- b) Liquid more viscous than desired.
- c) Suction or discharge lines obstructed.
- d) Mechanical defects.

(End thrust on pump shaft.)

(Tuthill pumps are not designed to take end thrust toward the pump cover and care must be taken to prevent thrust in this direction).

Drive shaft and pump shaft misaligned.

The pump may be binding due to insufficient end clearance. Pump shaft bent.

Misalignment within pump due to bad piping or poor installation, causing strains or distortion.

5. Pump is Noisy
 - a) Machine or part of it is acting as a sounding board.
 - b) Misalignment or bad design of coupling.
 - c) Coupling set too close to pump.
 - d) Vibration of pump because of bent shaft or worn parts.
 - e) Air leaks on suction side of pump.
 - f) Suction lift too high, causing vaporization.

6. Pump Leaks
 - a) Cover bolts need tightening, or cover gasket is defective.
 - b) Seal is defective or worn,

Material Returns

If it becomes necessary to return a pump to the factory, a Return Goods Authorization (RGA) must be obtained from either your local Authorized Distributor or our plant. No RGA can be issued until a completed Material Safety Data Sheet (MSDS) has been forwarded to our plant and return of the pump approved.

- Tuthill pumps are precision built and must be handled with care.
- Pumps must be drained of all fluid and the ports plugged to prevent foreign material from getting into the pump.
- Pumps must be packaged securely to prevent damage while in transit.